

REV	DESCRIPTION	DATE	DRN
00	Initial revision	27 JUN 06	ABD

DRAWING NOTES

GENERAL NOTES

 IF ANY DISCREPANCY OVER DIMENSIONS OR AREAS OF THE PART SHOULD ARISE, CONTACT THE NUMBER SHOWN BELOW

GENERAL TOLERANCES
 FLATNESS +/- 0.2MM UNLESS STATED
 TOLERANCES 013 OF ANY DIMENSION

INTERNAL BEND RADIUS 0.5MM
 'K' FACTOR TO BE DECIDED BY SUPPLIER

UNSPECIFIED BEND RELIEF = TEAR TYPE

BEND CENTER LINES DIMENSIONS IN PARENTHESIS E.G. (300.00)

ALL EDGES TO BE BEBURRED AND CLEAN PRIOR TO POWDERCOAT

ALL REAR PANEL CONNECTOR CUT OUTS SHOULD BE CLEAN OF EXCESS POWDERCOAT PRIOR TO PCB ASSEMBLY

MATERIAL: 1MM ZINC SEAL
 COLOUR: PRYTHONE Cool Gray 11C
 FINISH: POWDERCOAT

Opengear
 LEVEL 1, 80 JEPHSON ST
 TOOWONG
 QLD. 4066, AUSTRALIA
 TEL: +61 7 3227 8828
 FAX: +61 7 3227 8737

TOLERANCE UNLESS STATED
 0.3 = +/- 0.3mm
 0.00 = +/- 0.05mm

DO NOT DISCLOSE TO ANY THIRD PARTY WITHOUT WRITTEN CONSENT

MEASURE TWICE CUT ONCE

SIZE	SCALE	FILE NAME
A0	NTS	CM4008R_BASE_MCH_00.dwg

DRAWING TITLE	DATE
CM4008 RACK MOUNT BASE M/W SPECIFICATION	27 JUN 06

DESIGN	APPR
ABD	
CHECKED	

DRAWING NAME: CM4008R_BASE_MCH_00
 DO NOT SCALE FROM DRAWING

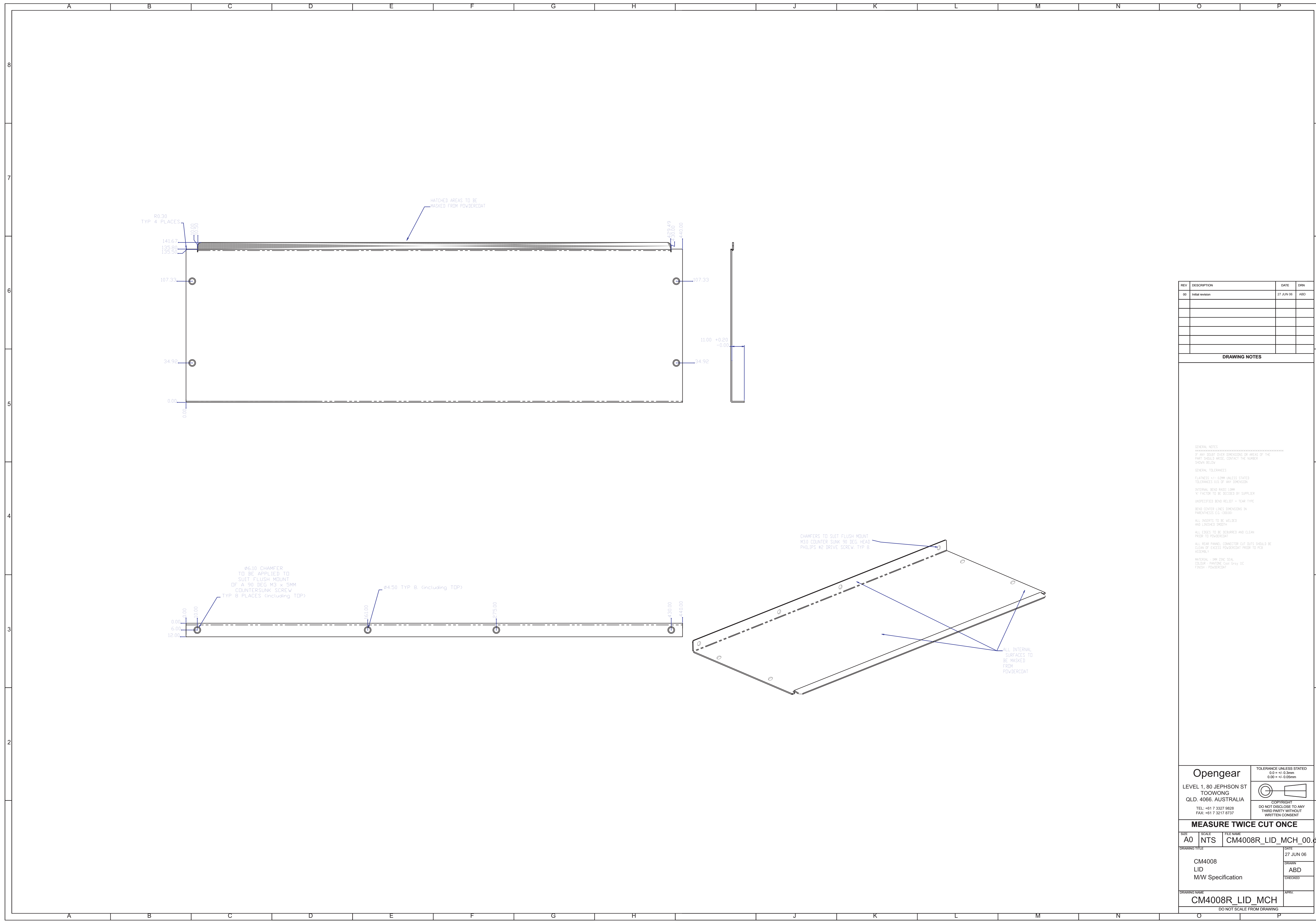

REV	DESCRIPTION	DATE	DRN
00	Initial revision	27 JUN 06	ABD

DRAWING NOTES

GENERAL NOTES
 IF ANY QUESTIONS CONCERNING THIS DRAWING OR THE PART SHOULD ARISE, CONTACT THE NUMBER GIVEN BELOW

GENERAL TOLERANCES
 DIMENSIONS ± 0.20 UNLESS STATED
 TOLERANCES 5% OF ANY DIMENSION

INTERNAL BEND RADIUS 1.5MM
 R1 FACTOR TO BE DECIDED BY SUPPLIER

UNSPECIFIED BEND RADIUS IF TEAR TYPE
 BEND CENTER LINE DIMENSIONS IN PARENTHESES (C) 0.000

ALL INSERTS TO BE WELDED AND LUNGHEID DIMEN

ALL EDGES TO BE DEBURRED AND CLEAN FROM POWDERCOAT

ALL REAR PANEL CONNECTOR CUT SLOTS SHOULD BE CLEAN OF EXCESS POWDERCOAT PRIOR TO PCB MOUNTING

MATERIAL - 1MM 20% ZINC COLOUR - PANTONE Cool Gray 10C FINISH - POWDERCOAT

Opengear
 LEVEL 1, 80 JEPHSON ST
 TOOWONG
 QLD. 4066, AUSTRALIA
 TEL: +61 7 3327 9828
 FAX: +61 7 3317 8737

DO NOT DISCLOSE TO ANY THIRD PARTY WITHOUT WRITTEN CONSENT

MEASURE TWICE CUT ONCE

SIZE	SCALE	FILE NAME	DATE
A0	NTS	CM4008R_LID_MCH_00.dwg	27 JUN 06
DRAWING TITLE			DRAWN
CM4008 LID			ABD
MW Specification			CHECKED
DRAWING NAME			APPV
CM4008R_LID_MCH			

DO NOT SCALE FROM DRAWING

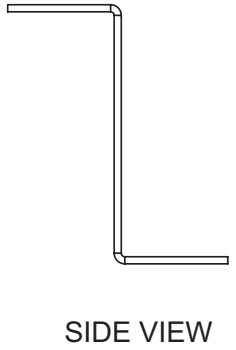
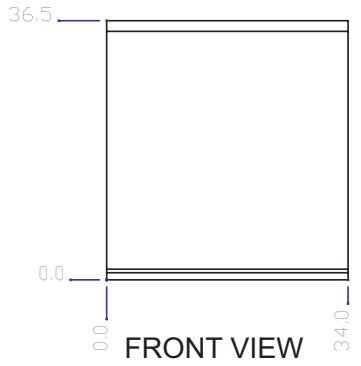
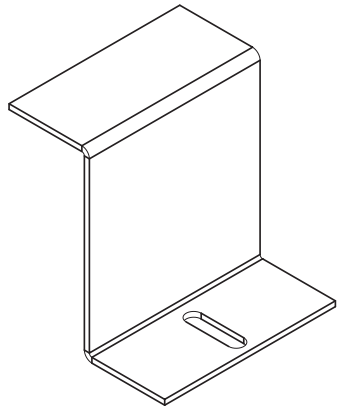
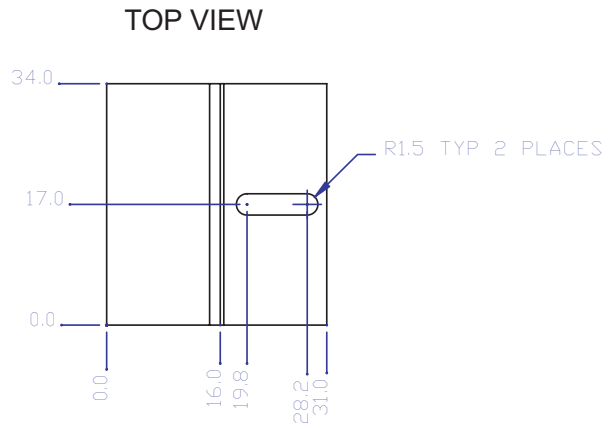

REV	DESCRIPTION	DATE	DRN
00	Initial revision	26 NOV 04	ABD

DRAWING NOTES

GENERAL NOTES

 IF ANY DOUBT OVER DIMENSIONS OR AREAS OF THE PART SHOULD ARISE, CONTACT THE NUMBER SHOWN BELOW

GENERAL TOLERANCES
 FLATNESS +/- 0.2MM UNLESS STATED
 TOLERANCES 0.1% OF ANY DIMENSION

INTERNAL BEND RADI 0.5MM
 'K' FACTOR TO BE DECIDED BY SUPPLIER

UNSPECIFIED BEND RELIEF = TEAR TYPE

BEND CENTER LINES DIMENSIONS IN PARENTHESIS E.G. (300.00)

ALL INSERTS TO BE WELDED AND UNISHED SMOOTH

ALL EDGES TO BE DEBURRED AND CLEAN PRIOR TO POWDERCOAT

ALL REAR PANNEL CONNECTOR CUT OUTS SHOULD BE CLEAN OF EXCESS POWDERCOAT PRIOR TO PCB ASSEMBLY

MATERIAL : 1MM ZINC SEAL
 COLOUR : PANTONE Cool Gray 11C
 FINISH : POWDERCOAT

Opengear

LEVEL 1, 80 JEPHSON ST
 TOOWONG
 QLD. 4066. AUSTRALIA

TEL: +61 7 3327 9828
 FAX: +61 7 3217 8737

TOLERANCE UNLESS STATED
 0.0 = +/- 0.3mm
 0.00 = +/- 0.05mm

COPYRIGHT
 DO NOT DISCLOSE TO ANY
 THIRD PARTY WITHOUT
 WRITTEN CONSENT

MEASURE TWICE CUT ONCE

SIZE	SCALE	FILE NAME
A4	NTS	CM4008R_SIDE_MCH_00.dwg

DRAWING TITLE	DATE
CM4008 RACK MOUNT INNER SIDE BRACKET M/W SPECIFICATION	29 JUN 06

DRAWING NAME	APRV.
CM4008R Side Bracket	

DO NOT SCALE FROM DRAWING

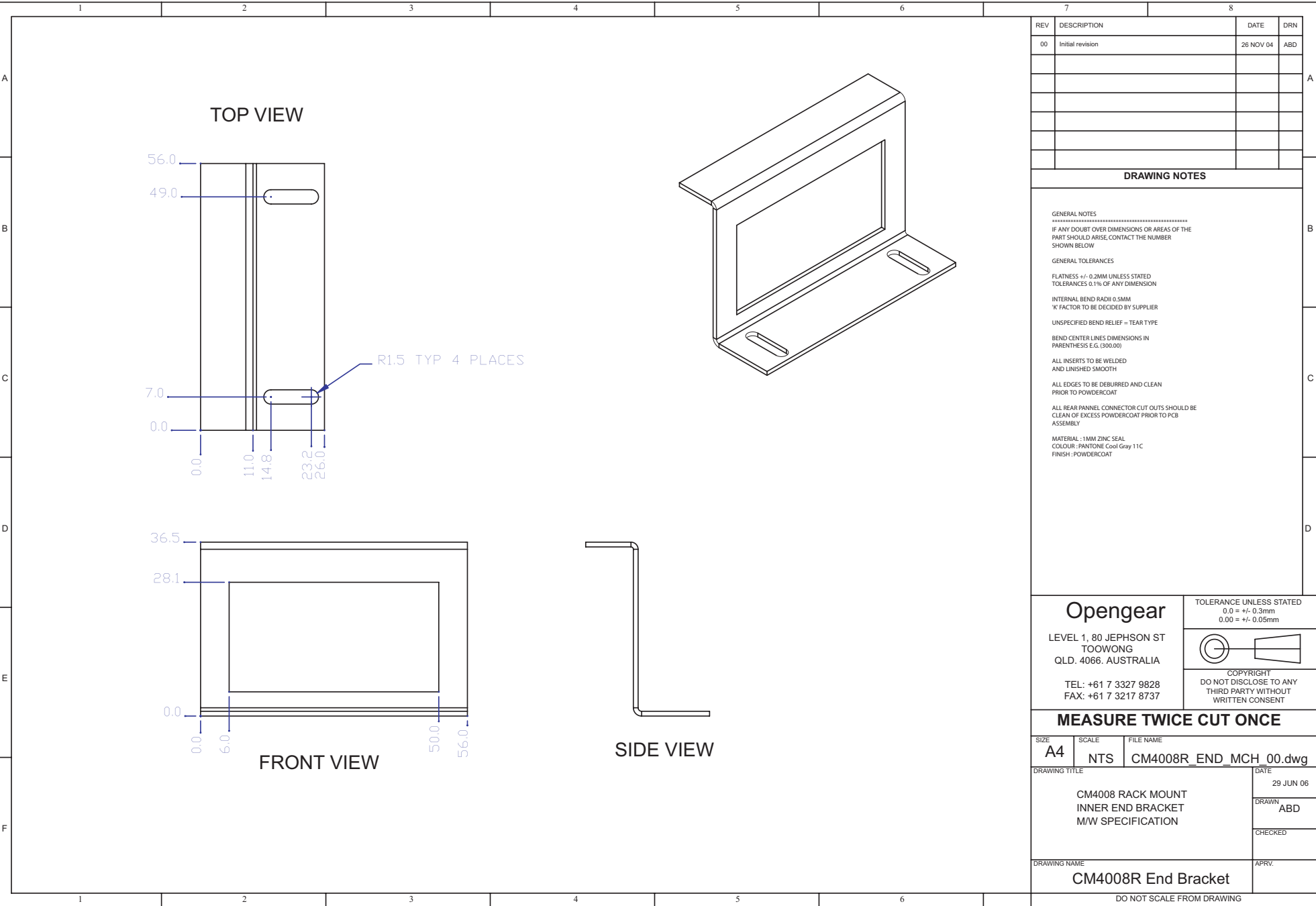

REV	DESCRIPTION	DATE	DRN
00	Initial revision	26 NOV 04	ABD

DRAWING NOTES

GENERAL NOTES

 IF ANY DOUBT OVER DIMENSIONS OR AREAS OF THE PART SHOULD ARISE, CONTACT THE NUMBER SHOWN BELOW

GENERAL TOLERANCES
 FLATNESS +/- 0.2MM UNLESS STATED
 TOLERANCES 0.1% OF ANY DIMENSION

INTERNAL BEND RADII 0.5MM
 'K' FACTOR TO BE DECIDED BY SUPPLIER

UNSPECIFIED BEND RELIEF = TEAR TYPE

BEND CENTER LINES DIMENSIONS IN PARENTHESIS E.G. (300.00)

ALL INSERTS TO BE WELDED AND FINISHED SMOOTH

ALL EDGES TO BE DEBURRED AND CLEAN PRIOR TO POWDERCOAT

ALL REAR PANNEL CONNECTOR CUT OUTS SHOULD BE CLEAN OF EXCESS POWDERCOAT PRIOR TO PCB ASSEMBLY

MATERIAL : 1MM ZINC SEAL
 COLOUR : PANTONE Cool Gray 11C
 FINISH : POWDERCOAT

Opengear

LEVEL 1, 80 JEPHSON ST
 TOOWONG
 QLD. 4066. AUSTRALIA

TEL: +61 7 3327 9828
 FAX: +61 7 3217 8737

TOLERANCE UNLESS STATED
 0.0 = +/- 0.3mm
 0.00 = +/- 0.05mm

COPYRIGHT
 DO NOT DISCLOSE TO ANY
 THIRD PARTY WITHOUT
 WRITTEN CONSENT

MEASURE TWICE CUT ONCE

SIZE A4	SCALE NTS	FILE NAME CM4008R_END_MCH_00.dwg
DRAWING TITLE CM4008 RACK MOUNT INNER END BRACKET M/W SPECIFICATION		DATE 29 JUN 06
DRAWING NAME CM4008R End Bracket		APRV. ABD

DO NOT SCALE FROM DRAWING